



## FLP Lens Series for LUXEON™ Rebel LEDs

- High efficiency
- Available in 4 different beams
- Easy assembly

The FLP lens series offers 4 lenses specifically designed for the Lumileds (1) LUXEON® Rebel LEDs.

A software-optimized aspheric profile combined with shaped front surfaces and Fresnel profiles, provide several different beam output patterns: narrow, medium, elliptical, and wide beams.

The high collection efficiency reaches 85% of the total flux emitted from the LED.

Lens holders are available in black, and provide the proper alignment between the LEDs and the lenses, and set the correct distance between the lens and LED.

The lens holder can be glued to the PCB to provide a secure assembly.

Typical applications are:

- Reading lamps
- Signs
- Architectural Lighting
- Street Lights



(1) LUXEON® Rebel is a trademark of Lumileds Lighting, LLC. For technical specification on LEDs please refer to the LUXEON® Rebel datasheet or visit <http://www.luxeon.com/> or <http://www.luxeon.com/products/line.cfm?lineid=19>

(2) Typical beam divergence may change with different color LEDs.

### FRAEN CORPORATION

80 Newcrossing Road  
Reading MA 01867  
Phone: 781.205.5300  
Fax: 781.942.2426  
[optics@fraen.com](mailto:optics@fraen.com)

### FRAEN Srl

Via Stelvio, 12  
20019 Settimo M. (MI) – Italy  
Phone: +39-02-35.456.1  
Fax: +39-02-335.456.239  
[info@fraen.it](mailto:info@fraen.it)

Website: [www.fraensrl.com](http://www.fraensrl.com)

Distributed by Future Electronics



Americas: 1-888-LUXEON2

[askluxeon@FutureElectronics.com](mailto:askluxeon@FutureElectronics.com)

Europe: 00-0800-44FUTURE

[luxeon.europe@FutureElectronics.com](mailto:luxeon.europe@FutureElectronics.com)

Asia: 1-800-LUMILEDS

[lumileds.asia@FutureElectronics.com](mailto:lumileds.asia@FutureElectronics.com)



## General Characteristics

---

|                             |                       |
|-----------------------------|-----------------------|
| Lens Material               | Optical Grade PMMA    |
| Holder Material             | PC/ABS                |
| Operating Temperature range | -40deg C / + 95 deg C |
| Storage Temperature range   | -40deg C / + 95 deg C |

Average transmittance in visible spectrum (400 – 700nm) >90%, as measured using 3mm thick Optical Grade PMMA.

*Please note that flow lines and weld lines on the external surfaces of the lenses are acceptable if the optical performance of the lens is within the specification described in the section "OPTICAL CHARACTERISTICS"*

### **IMPORTANT NOTE – Lenses handling and cleaning:**

- *Handling: Always use gloves to handle lenses and/or handle the lenses only by the flange. Never touch the outside surfaces of the lenses with fingers; finger oils and contamination will absorb or refract light.*
- *Cleaning: Clean lenses only if necessary. Use only soap and water to clean the surfaces and lenses. Never expose the lenses to alcohol, as it will damage the plastic.*

## Scope

---

This datasheet provides information about the FLP series lenses:





- FLP-N4-LLK2-0R
- FLP-M4-LLK2-0R
- FLP-W4-LLK2-0R
- FLP-E4-LLK2-0R

and lens assemblies:

- FLP-N4-RE-HRF
- FLP-M4-RE-HRF
- FLP-W4-RE-HRF
- FLP-E4-RE-HRF







## Optical Characteristics – Beam Angle (degrees, Full Angle)

| Lens Part Number | Beam Shape | Red, Orange, Amber<br> | Green<br> | Cyan Blue<br> | Cool White TFCC<br> | Warm White<br> |
|------------------|------------|---|--|--|--|---|
| FLP-N4-RE-HRF    | Narrow     | 11  | 11   | 12   | 11   | *   |
| FLP-M4-RE-HRF    | Medium     | 23  | 23   | 23   | 21   | *   |
| FLP-W4-RE-HRF    | Wide       | 41  | 40   | 36   | 36   | *   |
| FLP-E4-RE-HRF    | Elliptical | 11x44   | 11x41  | 11x44  | 13x44  | *   |

(1) The typical divergence varies with LED color due to different chip size and chip position tolerance. The typical total divergence is the full angle measured where the luminous intensity is half of the peak value.

## Optical Characteristics – On-Axis Intensity (candela/lumen)

| Lens Part Number | Beam Shape | Red, Orange, Amber<br> | Green<br> | Cyan Blue<br> | Cool White TFCC<br> | Warm White<br> |
|------------------|------------|---|--|--|--|---|
| FLP-N4-RE-HRF    | Narrow     | 23  | 22   | 16   | 18   | *   |
| FLP-M4-RE-HRF    | Medium     | 4   | 4  | 4  | 4  | *   |
| FLP-W4-RE-HRF    | Wide       | 2   | 2  | 2  | 2  | *   |
| FLP-E4-RE-HRF    | Elliptical | 5   | 5  | 4  | 4  | *   |

- (2) To calculate the on-axis intensity, multiply the on-axis efficiency of the lens (cd/lm) by the total flux of the Luxeon LED used. See “Illumination Calculations” below. For more detail on flux binning please check the Luxeon LED datasheet at <http://www.luxeon.com/>
- (3) Luminous intensity depends on the flux binning and tolerances of the LEDs. Please refer to the Luxeon datasheet for more details on flux binning and mechanical tolerances.
- (4) Typical illuminance measured in lux per lumen (E) with typical Luxeon™ LEDs. To estimate the illuminance in lux, multiply the typical illuminance E by the flux in lumen of the LED used. See “Illumination Calculations” below.

\* These results have not been measured.

## illumination Calculations

---

To calculate peak candela: Find the central spot “on-axis intensity” value in the table above, then multiply this value by the lumens output from your LED (refer to the Luxeon Rebel LED datasheet (<http://www.luxeon.com/pdfs/DS56.pdf>) for nominal lumens values. OR for a more accurate calculation, refer to the intensity “ranking” (binning) tables on the datasheet for the specific LED.

### Example calculations:

If the Fraen narrow beam lens FLP-N4-RE-0R is used on a cool white Luxeon Rebel LED at 350 mA, the typical luminous flux of the LED is 80 lumens:

The calculation is: (18 candela/lumen) x (60 lumens) = 1080 candela peak on-axis.

The beam angle specified in the table above is 10 degrees full beam-width measured at half-peak. This means at 5 degrees off-axis (half of 10 degrees), the intensity should be half of 1080 candela, or 540 candelas.

1 candela at 1-meter distance produces 1 Lux. This means the peak intensity at 1 meter will be 1080 lux. The intensity decreases as a function of the distance squared, so at 2 meters the peak intensity will be  $1080 / (2^2) = 270$  lux. At 3 meters distance, the peak intensity will be  $1080 / (3^2) = 120$  lux.

## Mechanical Characteristics

---

**Figure 1. Identifying the lenses by their front views**

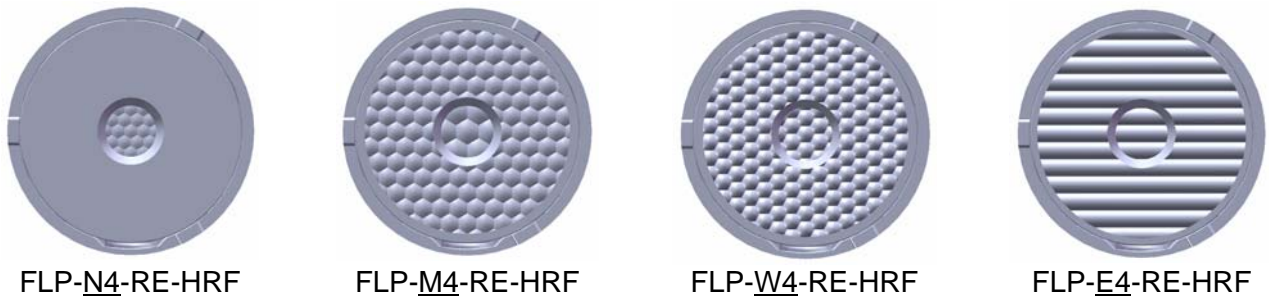

Continued on next page...



The FLP series lenses are available either assembled to a holder or without a holder. The holder provides the correct alignment (concentricity, height, and orientation) of the lens to the LED. Orientation control is important for the elliptical beam lens.

**Figure 2. Correct vertical position of the FLP lens and Luxeon Rebel LED**

**NOTE:** If the FLP lens is used with no lens holder, the user must provide a mechanical method to set the correct position of the lens on the LED. For example, the lens flange can be located in the lamp housing to center the lens to the LED and establish 10.8 mm from the lens flange to the user's PC board. When the lens is positioned correctly, the bottom of the lens touches the LED.

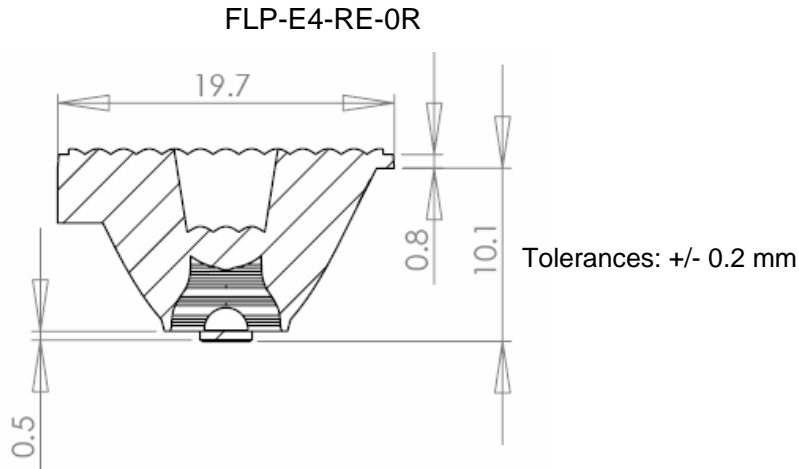

**Figure 3. Elliptical beam orientation**

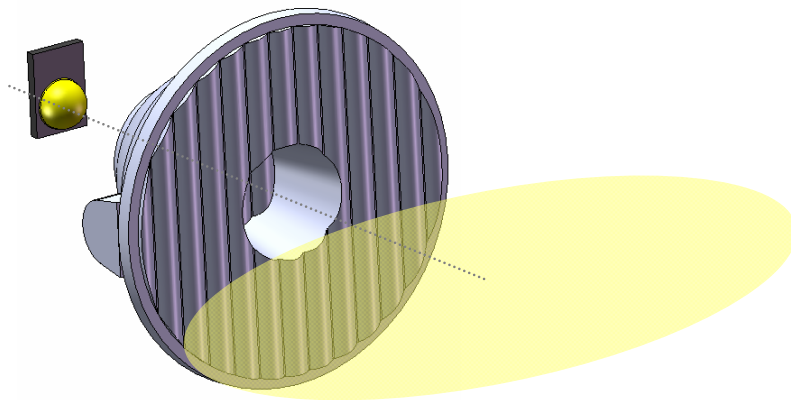

Elliptical beam and lens gate are horizontal.

The micro-lens pattern is vertical.

**NOTE:** The elliptical beam lens produces a beam shape that is perpendicular to the microlens pattern on the output face of the lens. The lens holder is designed to align the elliptical pattern with the shorter dimension of the Rebel LED. It is important to consider the orientation of the LEDs and the desired elliptical beam orientation when designing the printed circuit board layout.

**Figure 4. Installation of lens assembly onto Luxeon Rebel LED**

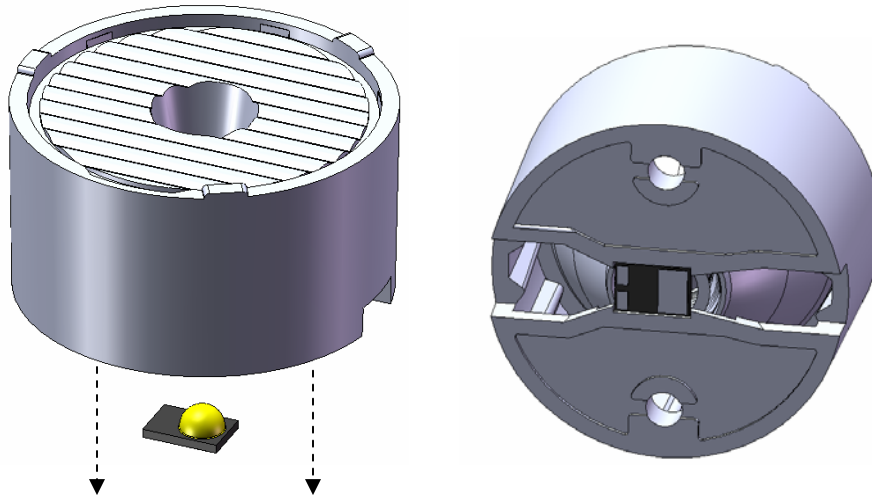

The FLP-E4-RE-HRF (and N4, M4 and W4) lens assemblies will fit onto the Luxeon Rebel LED at only 1 orientation. The bottom of this –HRF lens holder has a shape to control lens orientation (important for “E4” elliptical beam lens application). After installation, the bottom of the holder should be at the same datum/plane as the bottom of the Rebel LED.

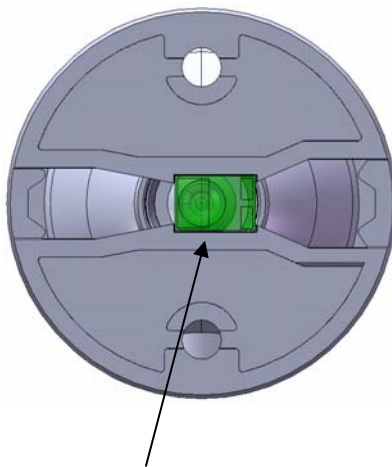

The LED package will fit into the square hole in the lens holder. This will align the lens to the LED.

Recessed areas for glue thickness and migration.

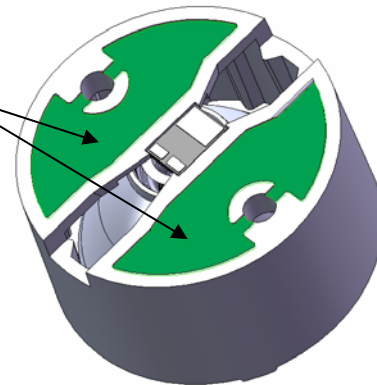

The lens assembly can be secured to the PC board by using glue or silicone RTV. To avoid glue on the lens and LED, apply it along the outside diameter edge, or apply a very thin film on areas shown in green.

**CAUTION:** Do not use “instant” glue (containing cyanoacrylates). Always test the glue on a sample assembly and check the results and performance 24 hours later. Some adhesives produce fumes that will damage the surfaces of the plastic lens, lens holder, or LED. Fraen recommends Henkel Loctite Hysol® E-90FL™ 2-component epoxy.

[Datasheet: Loctite Hysol® E-90FL™ epoxy](#)



**Figure 5. Overall dimensions of FLP- 4-RE-HRF series lens assemblies**

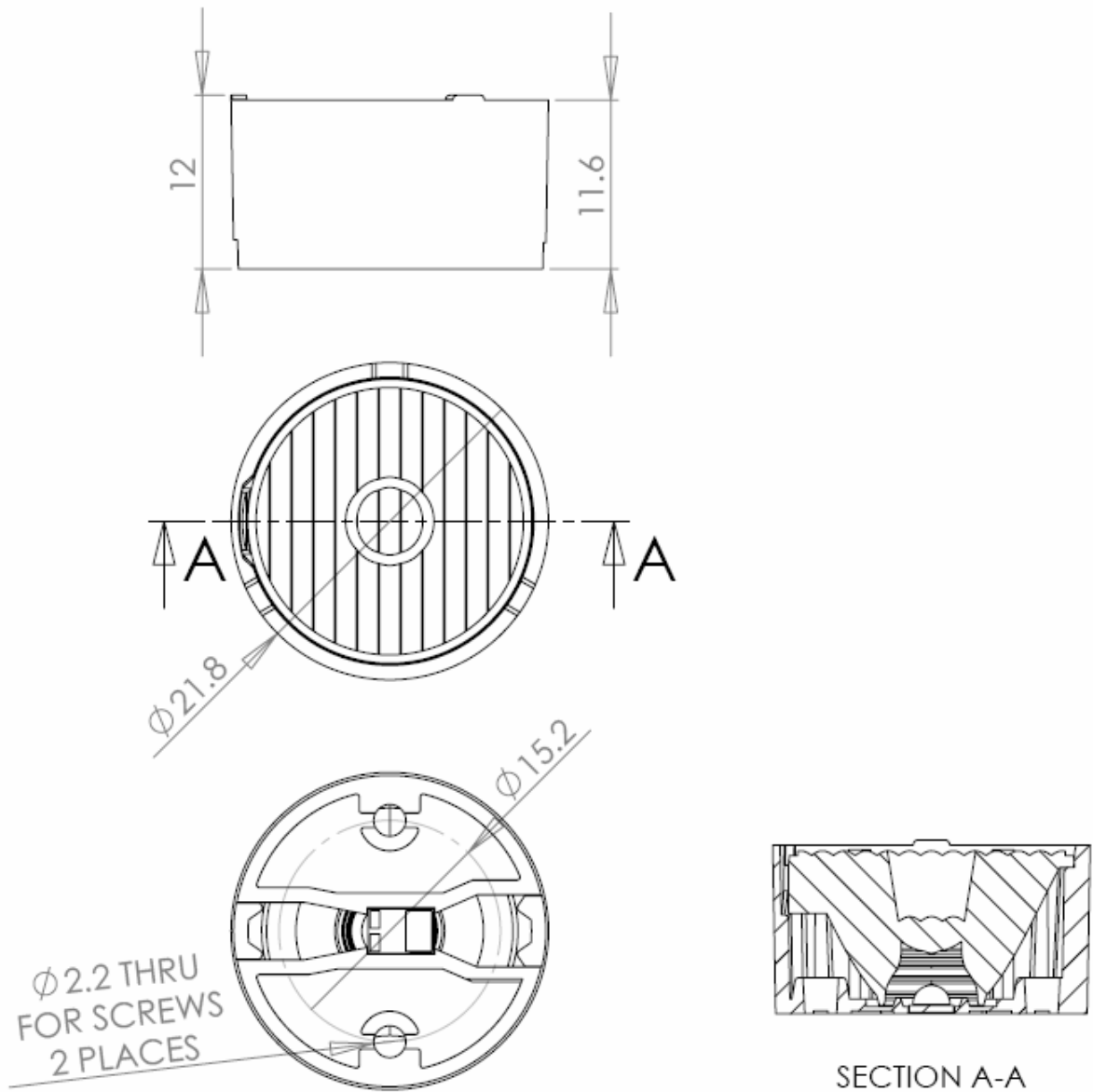



## Ordering part numbers

---

For lens only (no holder)

**FLP-\_4-LLK2-0R**



N: Narrow beam  
M: Medium beam  
W: Wide beam  
E: Elliptical beam

**Caution:** If using lens alone (with no holder), lens alignment and spacing must be set by the user. See Figure 2.

For assembly (lens + holder)

**FLP-\_4-RE-HRF**



N: Narrow beam  
M: Medium beam  
W: Wide beam  
E: Elliptical beam

**Caution:** The orientation of the elliptical beam lens is controlled by the lens holder and the LED orientation (see Figure 3).

*Published by Fraen Corporation.*

*All data contained in this document is the property of Fraen Corporation and may change without notice.*

| Rev | Date            | Author   | Description     |
|-----|-----------------|----------|-----------------|
| 00  | 04 January 2008 | C. Jones | Initial Release |